

TECHNICAL DATA

Voltage	<i>nominal</i>	105	kV
	<i>maximum for test</i>	120	
Inverse voltage	<i>nominal</i>	120	kV
	<i>maximum for test</i>	135	
Focal spot (IEC 60336:2005)		0.5	mm
Filament characteristics		4.0 ÷ 8.0	V
		2.5 ÷ 4.0	A
Anode material		tungsten	
Target angle		5	°
Anode heat storage capacity		30000	J
Maximum anode cooling rate		250	W
Nominal anode input power at 0.1 s (DC)		2000	W
Inherent filtration		0.5 mm Al	
Maximum diameter		42	mm
Overall length		138	mm

DIMENSIONS

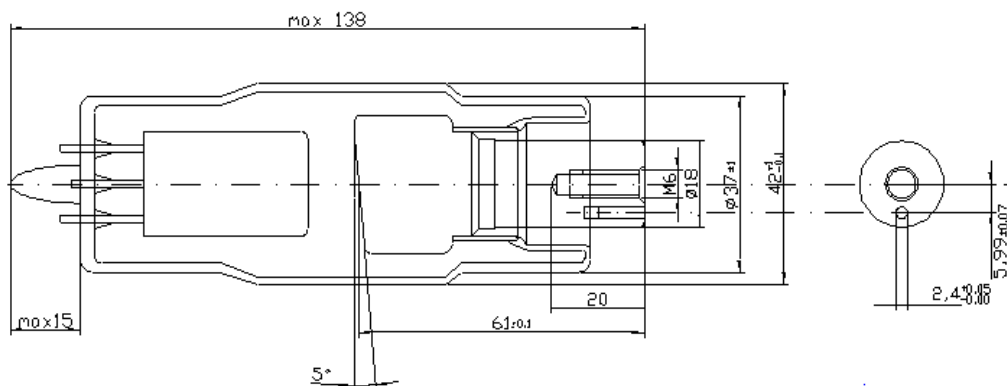

GENERAL INFORMATIONS

When mounting tube inserts adopt proper caution, in order to avoid glass bulb breaking and fragments projection. Please use protective gloves and glasses.

Tube insert connected to H.V. supply is a radiation source: be sure to take all necessary safety cautions

- Wash thoroughly with alcohol the external surface of tube insert (care of fire risk). Avoid contact of dirty surfaces with cleaned tube insert.
- Clamp system inside housing or self-contained units must not mechanically stress the tube.
- After installation, check the right working of the tube (no fluctuation of tube current nor crackling)
- Comply with insert thermal parameters, planning and programming the exposure parameters and cooling pauses. Housing or self-contained units must be provided with an adequate thermic protection.
- Voltages indicated in charts are valid for transformer supplied with ground center.
- Tube inserts contain environment polluting materials, particularly lead liner tubes. Please apply to qualified operator for waste disposal, according to local regulation requirements.

INCIDENT REPORT ACCORDING TO 93/42/EEC MEDICAL DEVICES DIRECTIVE

In order to comply with CE marking requirements, end users have to report to local Competent Authority all the informations about possible incidents involving the device, regarding any deterioration in its characteristics and performances, as well as any inaccuracies in this documentation, which might lead to or might have led to the death of patient / user or a deterioration in his state of health. This information must be promptly reported also to C.E.I. in order to start manufacturer reporting, as per above mentioned directive.



this mark assures device conformity to
EC Directive 93/42 on Medical Devices Safety.



THERMAL CURVES

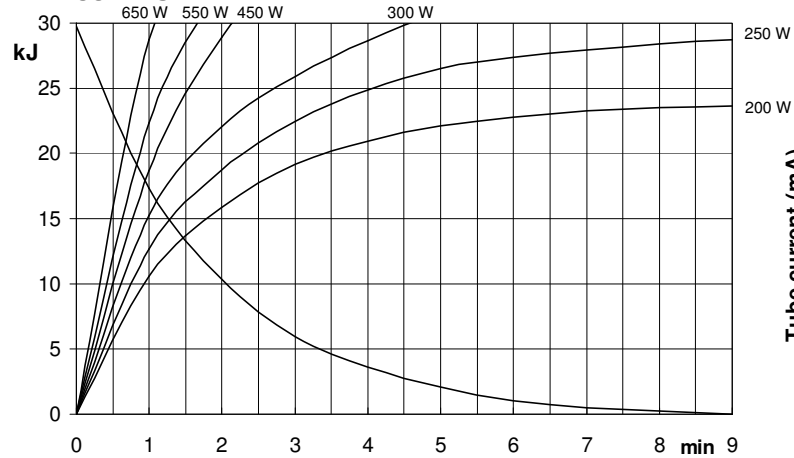

EMISSION CHARACTERISTICS

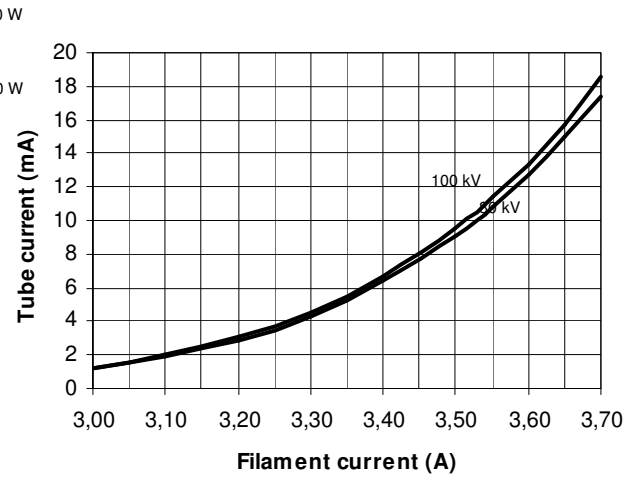

FILAMENT CHARACTERISTICS

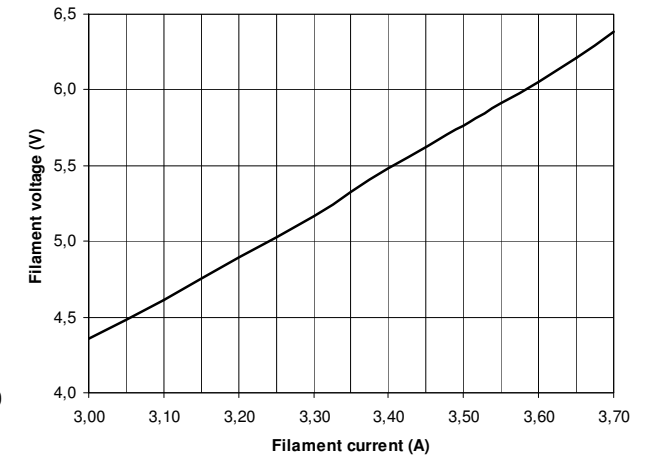

RATING CHARTS

