



TECHNICAL DATA

Voltage	nominal	120	kV
	maximum for test	135	
Inverse voltage	nominal	120	kV
	maximum for test	135	
Focal spots (IEC 60336:2005)	small	0.5	mm
	large	1.5	
Filament characteristics	small	3.4 ÷ 5.0 V 2.8 ÷ 3.4 A	
	large	2.7 ÷ 5.8 V 3.0 ÷ 4.5 A	
Anode material		tungsten	
Target angle		15	°
Anode heat storage capacity		30000*	J
Maximum anode cooling rate		270*	W
Nominal anode input power at 0.1 s (DC)	small	1000	W
	large	3800	
Inherent filtration		0.5 mm Al	
Maximum diameter		50	mm
Overall length		145*	mm

* with standard shank. On every kind of shank it is possible to make customized millings for the alignment of the tube.

GENERAL INFORMATIONS

When mounting tube inserts adopt proper caution, in order to avoid glass bulb breaking and fragments projection. Please use protective gloves and glasses.

Tube insert connected to H.V. supply is a radiation source: be sure to take all necessary safety cautions

- Wash thoroughly with alcohol the external surface of tube insert (care of fire risk). Avoid contact of dirty surfaces with cleaned tube insert.
- Clamp system inside housing or self-contained units must not mechanically stress the tube.
- After installation, check the right working of the tube (no fluctuation of tube current nor crackling)
- Comply with insert thermal parameters, planning and programming the exposure parameters and cooling pauses. Housing or self-contained units must be provided with an adequate thermic protection.
- Voltages indicated in charts are valid for transformer supplied with ground center.
- Tube inserts contain environment polluting materials, particularly lead liner tubes. Please apply to qualified operator for waste disposal, according to local regulation requirements.

INCIDENT REPORT ACCORDING TO 93/42/EEC MEDICAL DEVICES DIRECTIVE

In order to comply with CE marking requirements, end users have to report to local Competent Authority all the informations about possible incidents involving the device, regarding any deterioration in its characteristics and performances, as well as any inaccuracies in this documentation, which might lead to or might have led to the death of patient / user or a deterioration in his state of health. This information must be promptly reported also to C.E.I. in order to start manufacturer reporting, as per above mentioned directive.



this mark assures device conformity to EC Directive 93/42 on Medical Devices Safety.

DIMENSIONS AND CONNECTIONS

STD SHANK (Anode heat storage capacity 30 kJ, Maximum anode cooling rate 270 W)

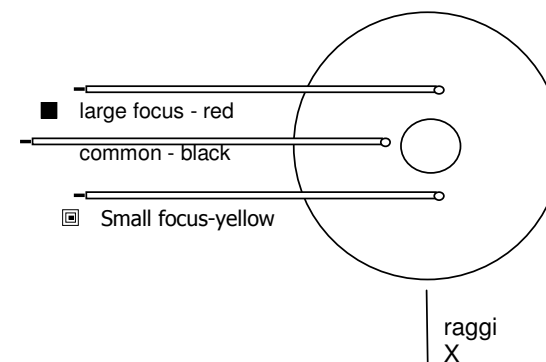
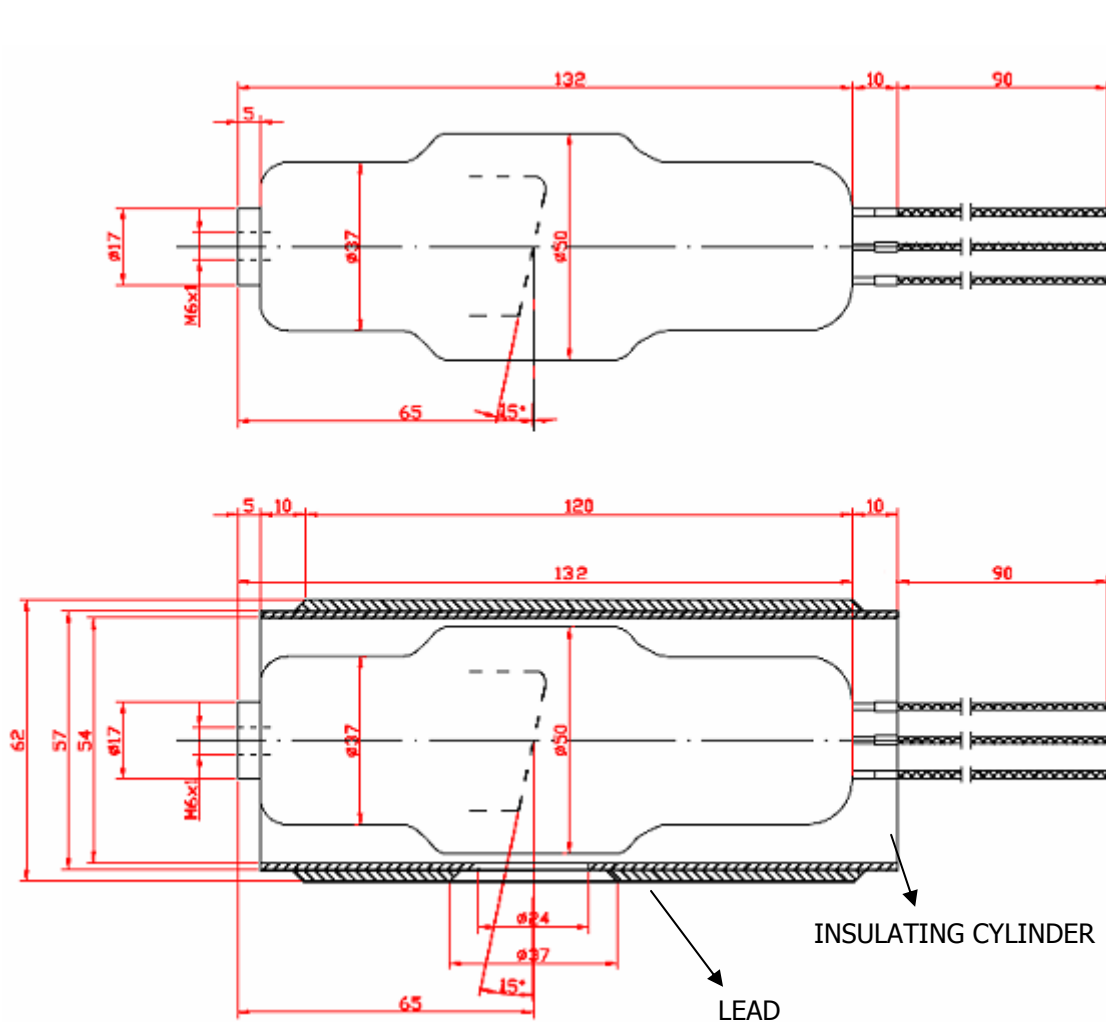

THERMAL CURVES

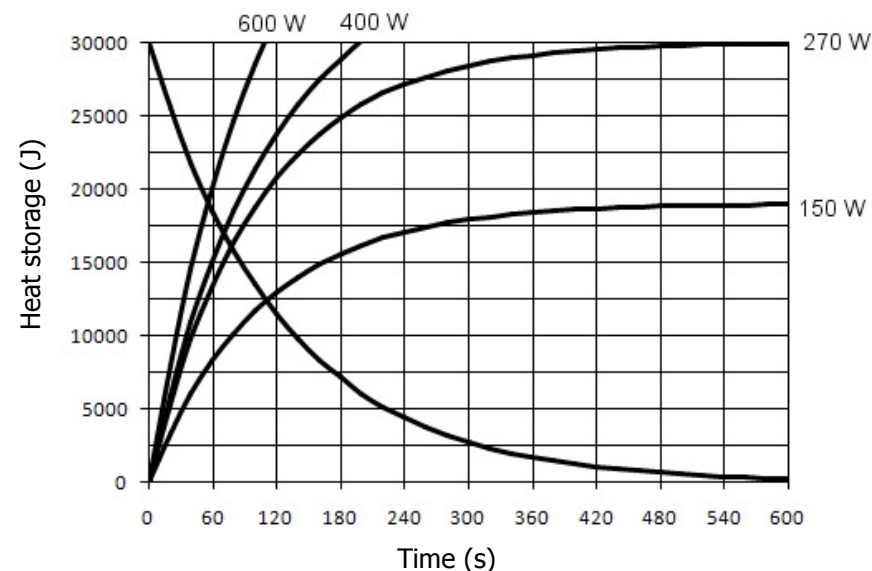

DIMENSIONS AND CONNECTIONS

LONG SHANK (Anode heat storage capacity 33 kJ, Maximum anode cooling rate 280 W)

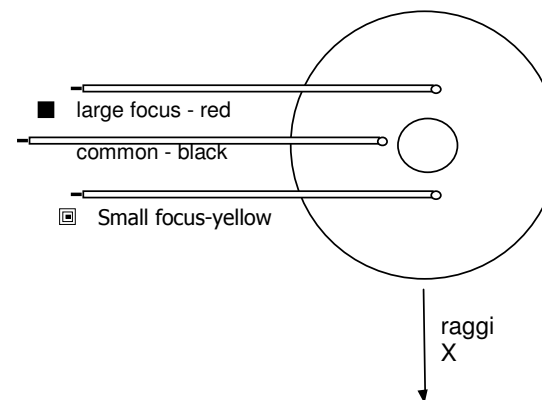
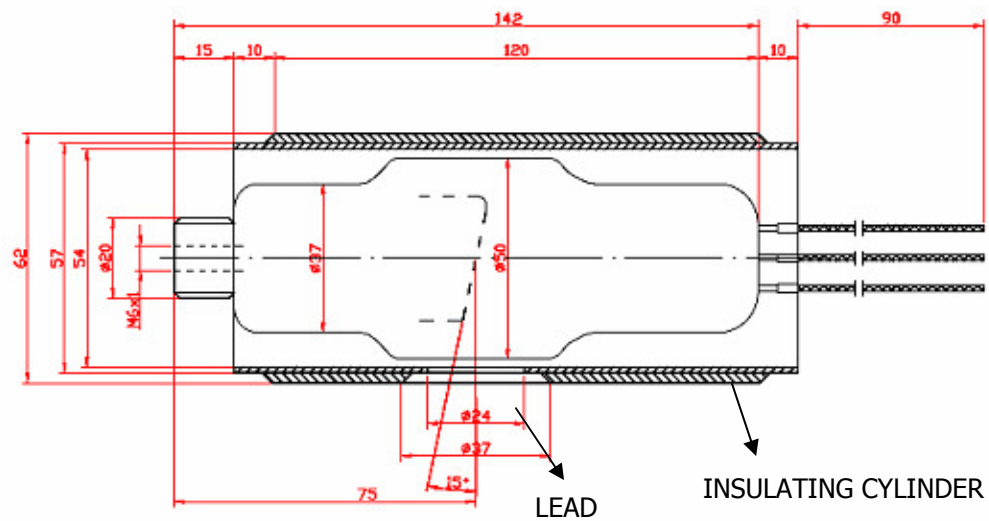
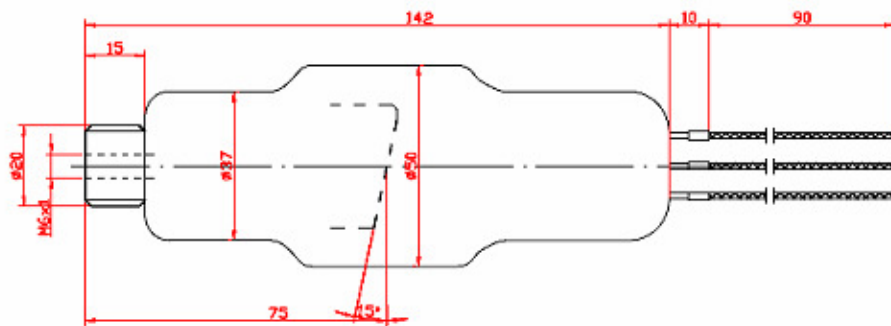

THERMAL CURVES

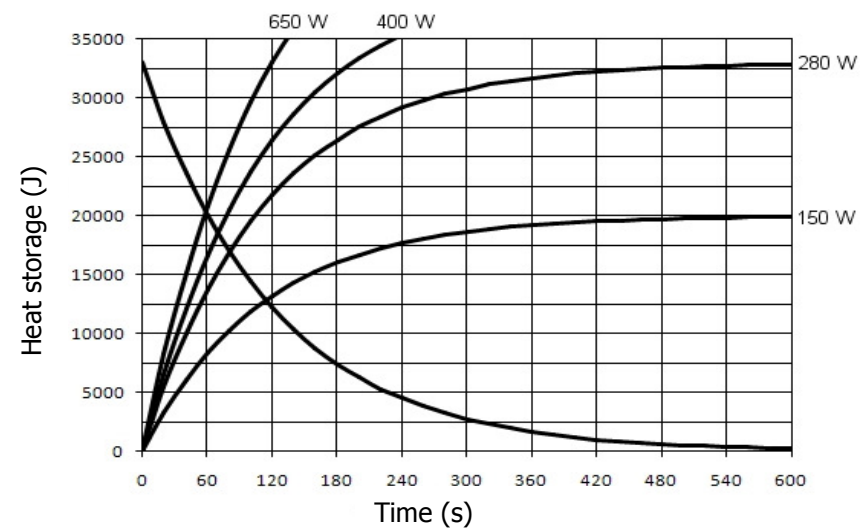

DIMENSIONS AND CONNECTIONS

RADIATOR (Anode heat storage capacity 40 kJ, Maximum anode cooling rate 500 W)

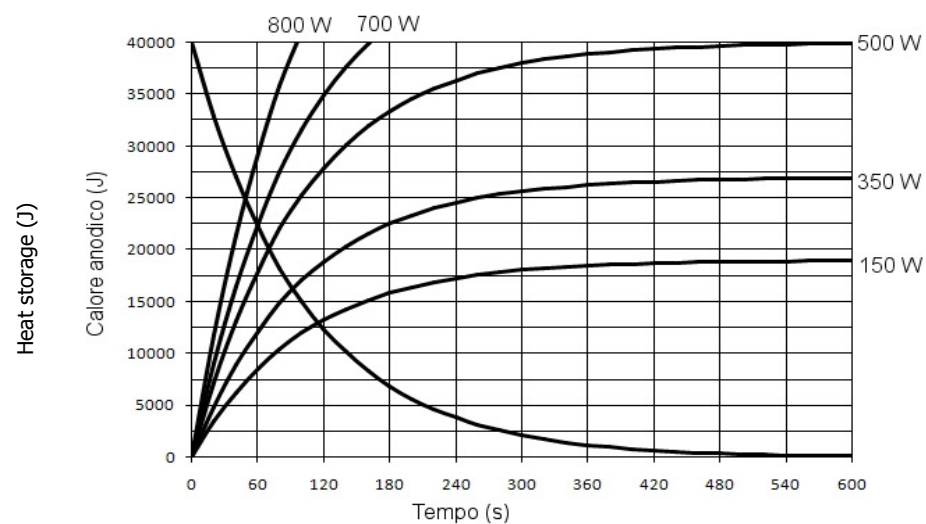
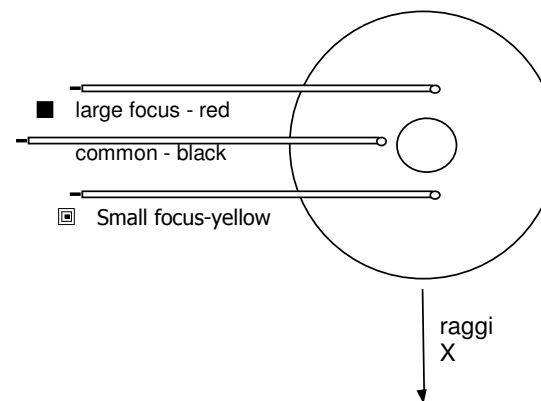
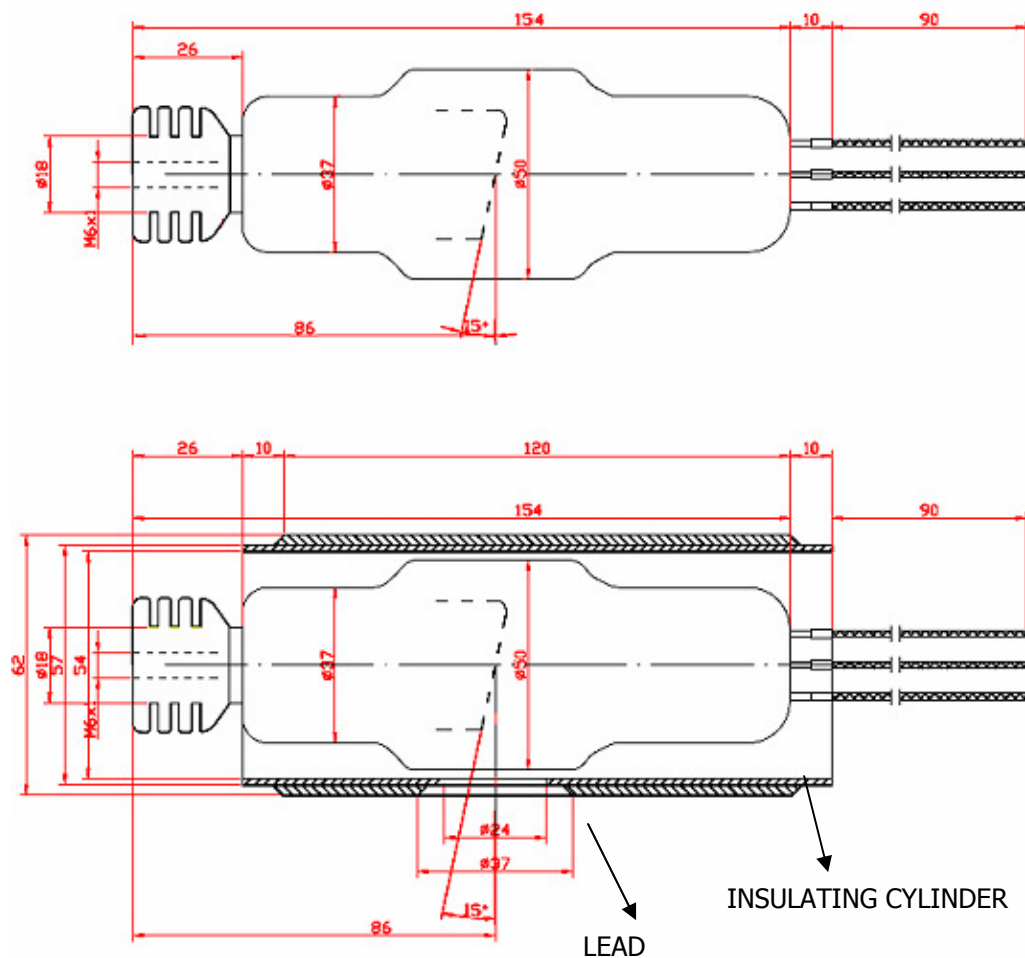



EMISSION CHARACTERISTICS

FILAMENT CHARACTERISTICS

RATING CHARTS DC

SMALL FOCAL SPOT (0.5 IEC 336)

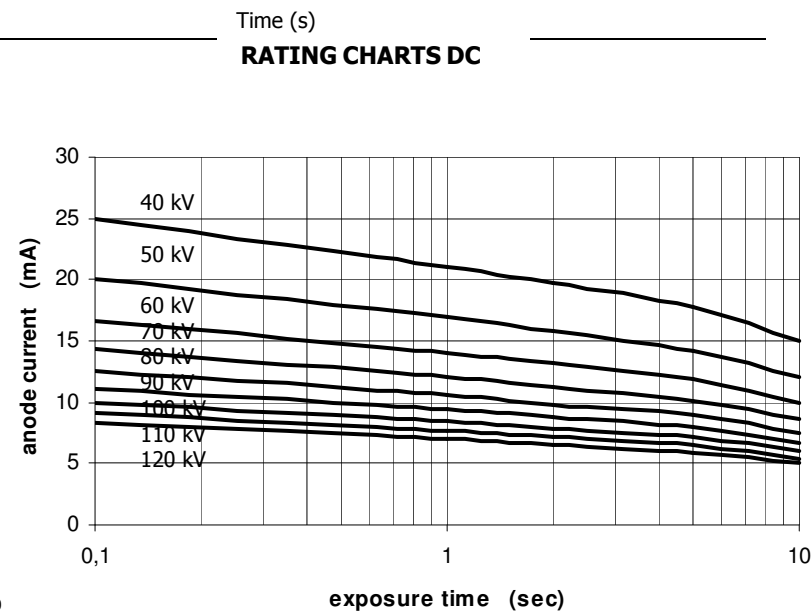
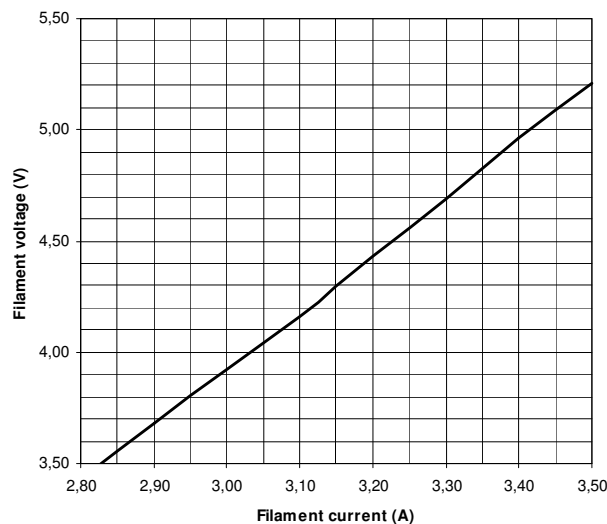
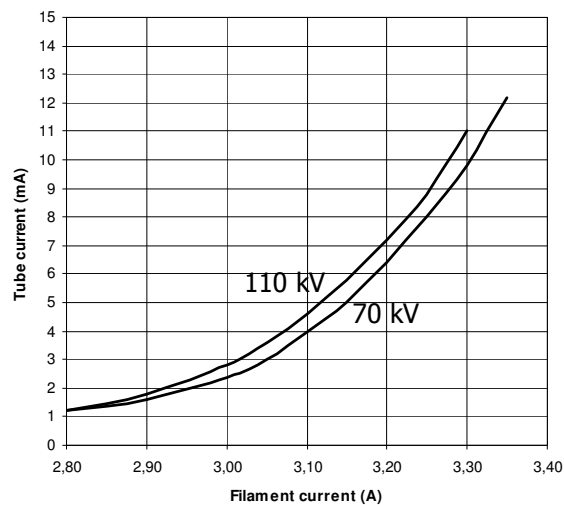

LARGE FOCAL SPOT (1.5 IEC 336)

