



## TECHNICAL DATA

Voltage	nominal	120	kV
	maximum for test	132	
Focal spot ((IEC60336:2005)	Small	0,3	mm
	Large	0,7	mm
Filament characteristics	Small	1,8 ÷ 3,0	V
		2,8 ÷ 3,5	A
	Large	3,2 ÷ 5,0	V
		2,8 ÷ 3,7	A
Maximum grid voltage		2000	V
Maximum dark current @ 1800 V -120 kV		<100	µA
Anode material		Tungsten	
Target angle		12	°
Anode heat storage capacity*		33000*	J
Maximum anode cooling rate*		280*	W
Nominal anode input power at 0.1 s (DC)	Small	620	W
	Large	1900	W
Inherent filtration		0,5 mm Al	
Maximum diameter		50,	mm
Overall length*		162 max*	mm
Weight (without lead shield)*		380	g

\* with std shank

## GENERAL INFORMATIONS

When mounting tube inserts adopt proper caution, in order to avoid glass bulb breaking and fragments projection. Please use protective gloves and glasses.  
 Tube insert connected to H.V. supply is a radiation source: be sure to take all necessary safety cautions

- Wash thoroughly with alcohol the external surface of tube insert (care of fire risk). Remove any labels on the glass bulb. Avoid contact of dirty surfaces with cleaned tube insert.
- Clamp system inside housing or self-contained units must not mechanically stress the tube.
- After installation, check the right working of the tube (no fluctuation of tube current nor crackling)
- Comply with insert thermal parameters, planning and programming the exposure parameters and cooling pauses. Housing or self-contained units must be provided with an adequate thermal protection.
- Voltages indicated in charts are valid for transformer supplied with ground center.
- Tube inserts contain environment polluting materials, particularly lead liner tubes. Please apply to qualified operator for waste disposal, according to local regulation requirements.

## INCIDENT REPORT ACCORDING TO 93/42/EEC MEDICAL DEVICES DIRECTIVE

In order to comply with CE marking requirements, end users have to report to local Competent Authority all the information about possible incidents involving the device, regarding any deterioration in its characteristics and performances, as well as any inaccuracies in this documentation, which might lead to or might have led to the death of patient / user or a deterioration in his state of health. This information must be promptly reported also to C.E.I. in order to start manufacturer reporting, as per above mentioned directive.



this mark assures device conformity to EC Directive 93/42 on Medical Devices Safety.

## CONNECTIONS

# PIN DISPOSAL

(CATHODE SIDE VIEW)

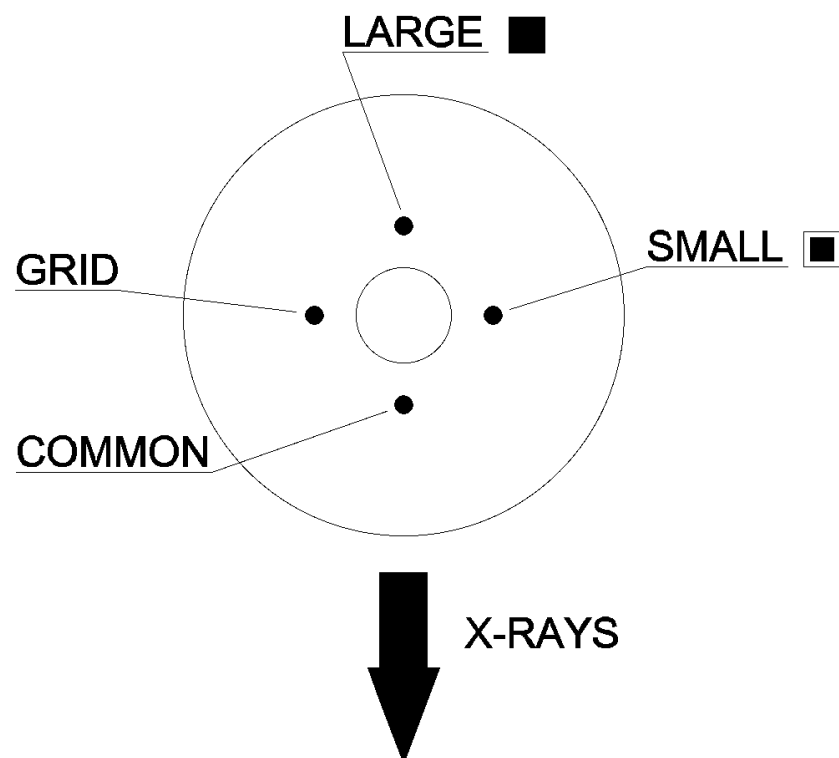



## DIMENSIONS STD SHANK

WEIGHT: 380 g

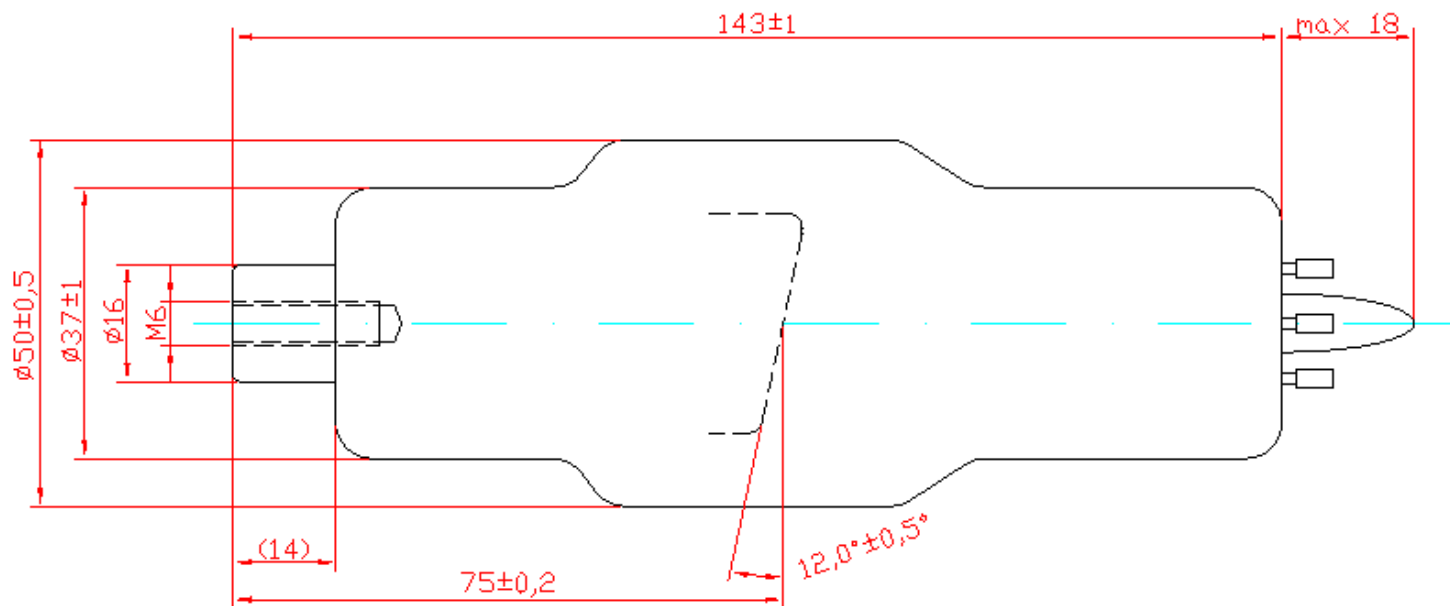



## DIMENSIONS STD SHANK WITH LEAD SHIELD

WEIGHT: 900 g

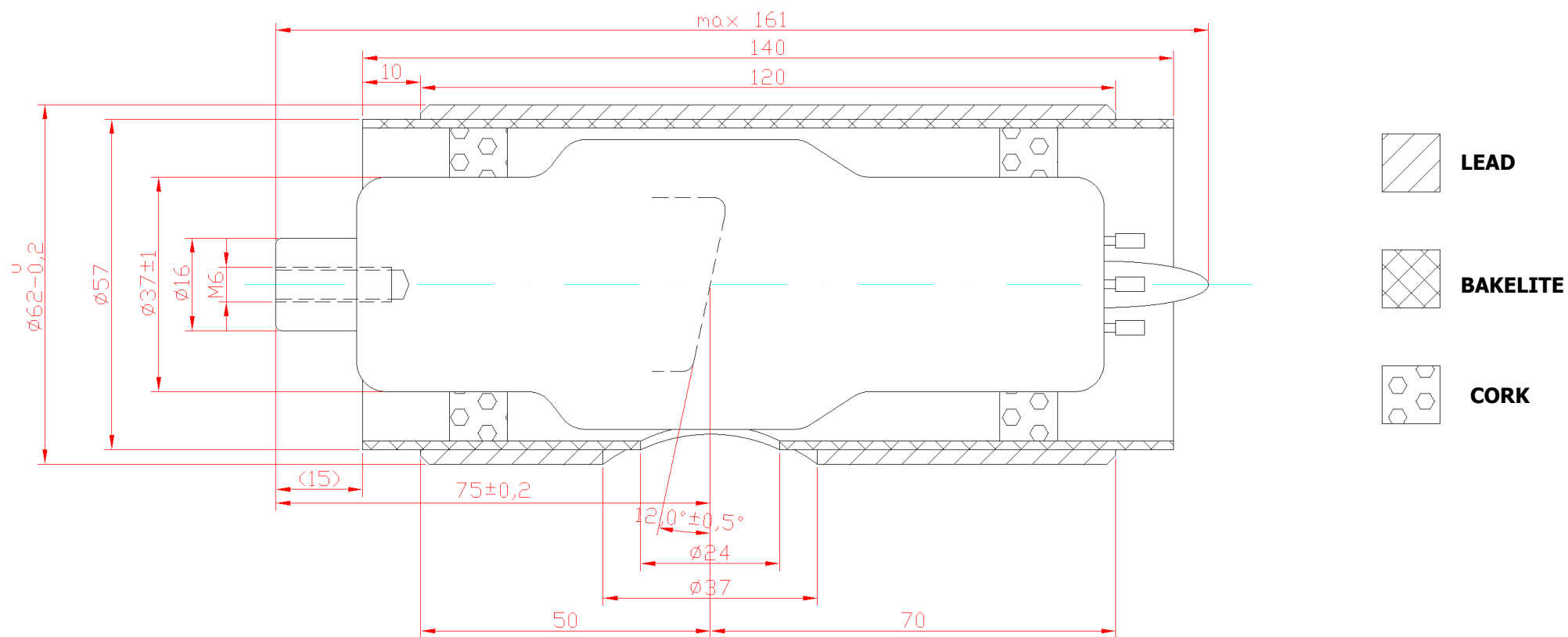



## THERMAL CURVES STD SHANK

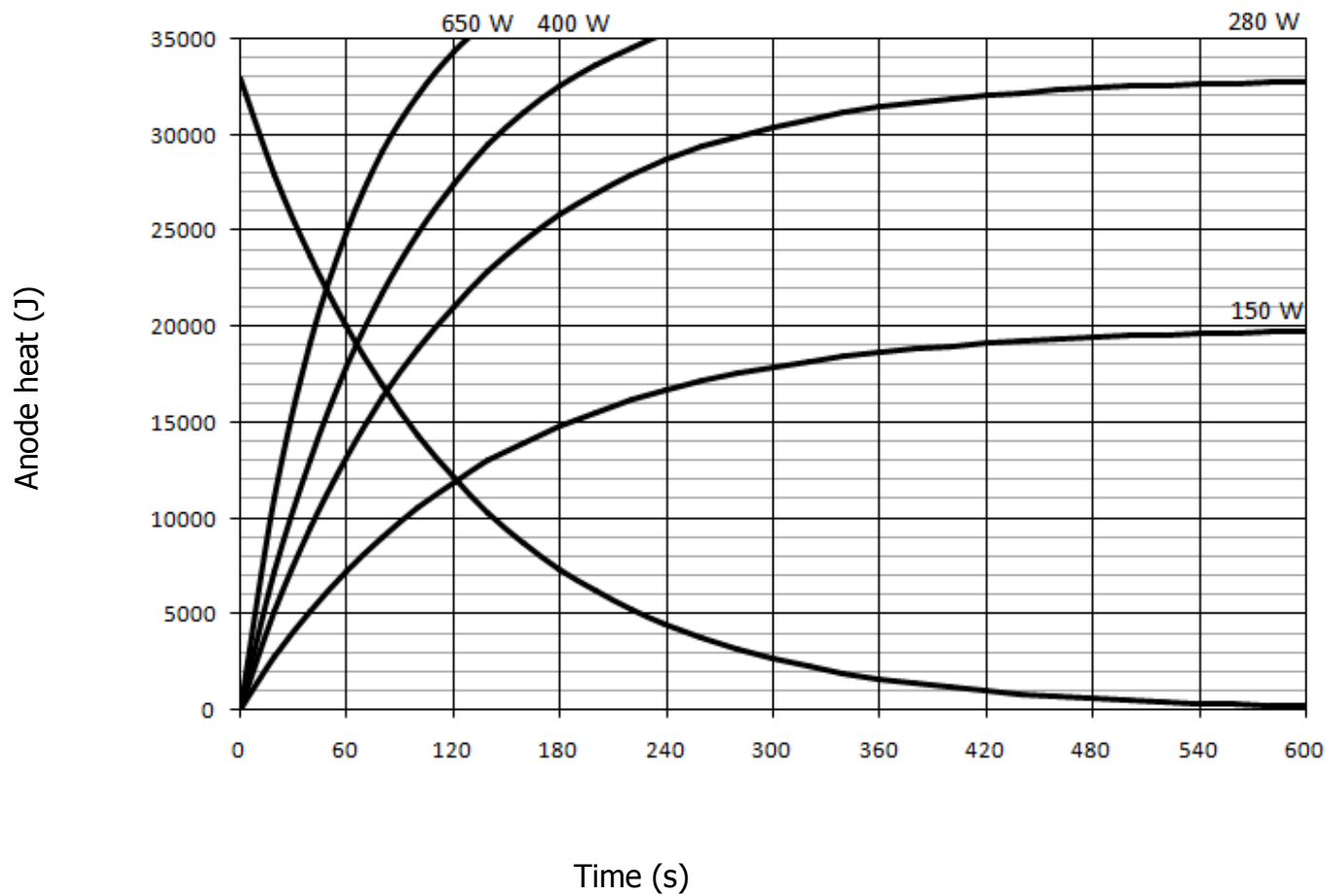



## FILAMENT CHARACTERISTICS

## EMISSION CHARACTERISTICS DC

SMALL FOCAL SPOT (0,3)

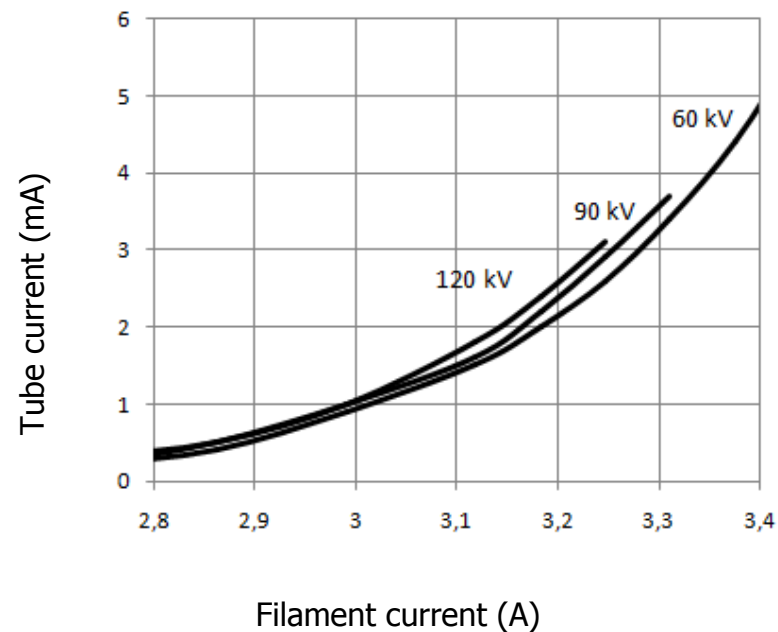
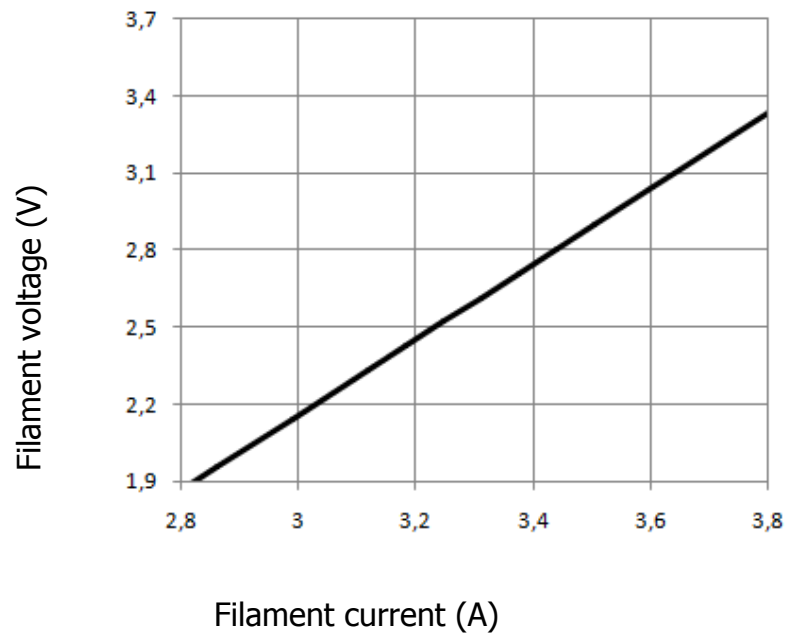



## RATING CHARTS DC

SMALL FOCAL SPOT (0,3)

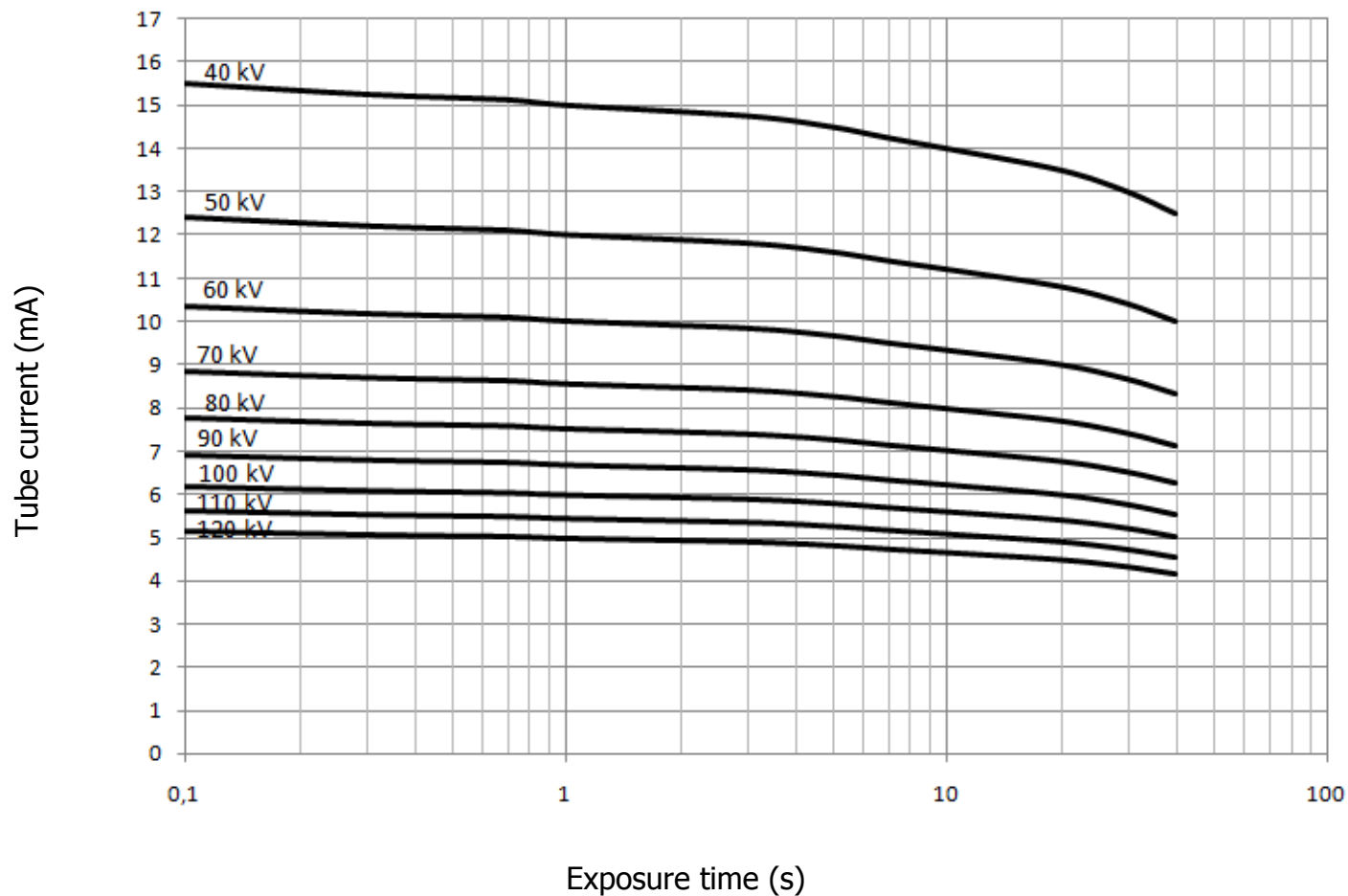

**Note:** This power rating has been verified in a large oil tank. Power rating may vary depending upon the oil capacity as well as the oil circulation in the testing tank.



## FILAMENT CHARACTERISTICS

## EMISSION CHARACTERISTICS DC

LARGE FOCAL SPOT (0,7)

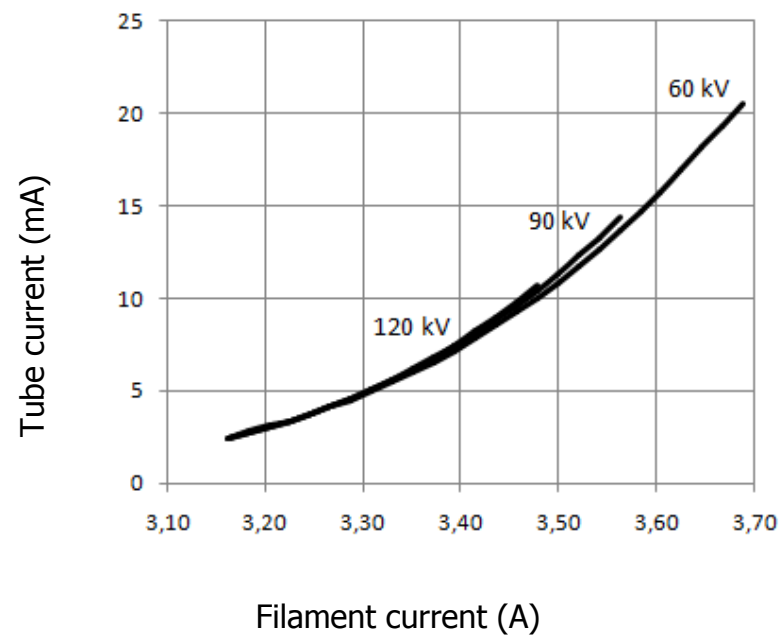
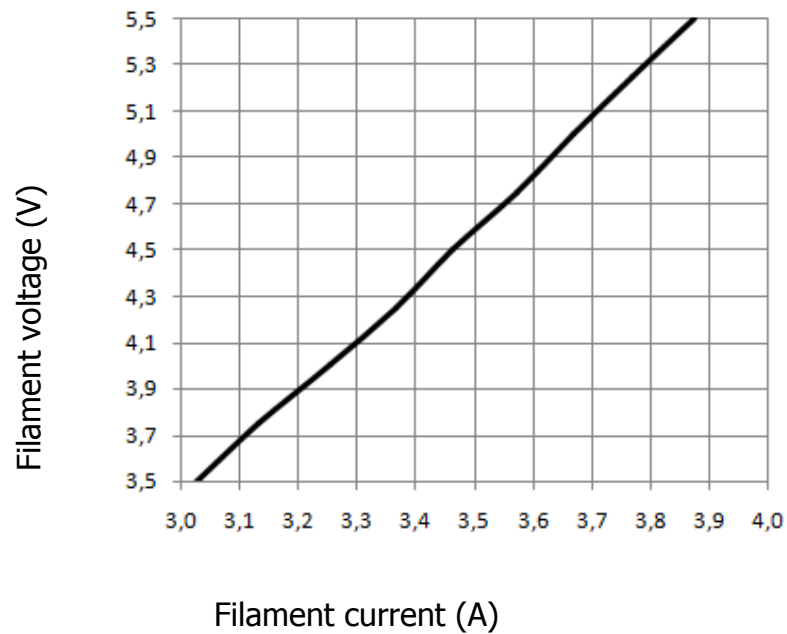





## RATING CHARTS DC

LARGE FOCAL SPOT (0,7)

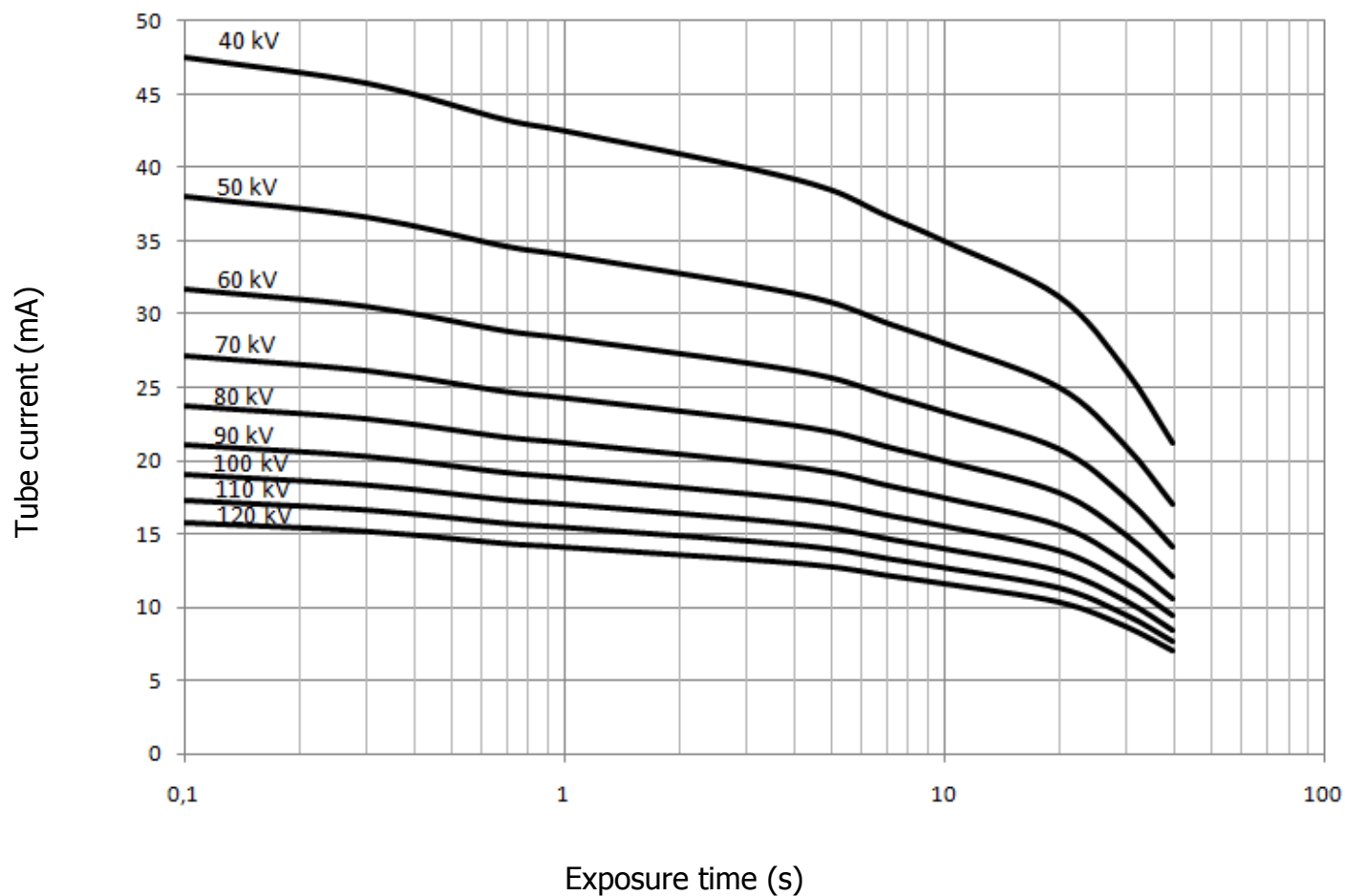

**Note:** This power rating has been verified in a large oil tank. Power rating may vary depending upon the oil capacity as well as the oil circulation in the testing tank.

**INFORMATION:**

Even if the tube is shipped after a long seasoning and testing cycle, it is always better to perform a quick seasoning before the first exposure. Please start the test cycle with the lowest kV possible in your machine, and increase the kV gradually with an incremental step of 5kV. For each step, perform at least 3 exposures maintaining the current parameter between 1mA and 2mA. A gap of few seconds between each of the exposures is advised. Increase the kV to the max kV as rated for the respective tube. In case of instability observed, reduce kV by one step. Once the kV reaches the nominal kV allowed for the respective tube, perform 3 exposures at the nominal power as requested for the concerned application.

Full seasoning is not required, when installing the machine. Nevertheless, if the tube head has been stored for more than 6 months, it is advised to perform few exposures at low kV and low power, before sending the machine to the final customer.